

Before the
FEDERAL COMMUNICATIONS COMMISSION
Washington, D.C. 20554

In the Matter of)
)
THE BELL ATLANTIC TELEPHONE)
COMPANIES)
)
Offer of Comparably Efficient)
Interconnection to Providers)
Of Gateway Services)

AMENDMENT TO CEI PLAN

In the Order approving Bell Atlantic's comparably efficient interconnection ("CEI") plan for gateway service, the Chief, Common Carrier Bureau, found the description of two adjunct services -- electronic mail ("E-Mail") and computer storage -- were insufficiently detailed to permit approval of these services.^{1/} This filing supplements the record to provide greater specificity about these two features.

In all respects, Bell Atlantic will comply with CEI requirements in the manner described in its CEI plan and approved in the Order. All underlying basic services and interfaces are those set out in that Plan. The Commission

^{1/} Memorandum Opinion and Order, DA 88-1512, released September 30, 1988 ("Order") at ¶17.

should approve this amendment expeditiously in order to allow the public to enjoy the benefits of a comprehensive gateway service at the earliest possible time.

As set out in detail in Attachment A, Bell Atlantic will offer, under Bell Atlantic's name, an existing E-Mail service.^{2/} The service will be connected to the gateway processor through Bell Atlantic's Public Data Network ("PDN") service, in the same manner as any other enhanced service provider that uses the gateway.^{3/} Bell Atlantic will "private label" an existing E-Mail service, and all underlying basic services shown in Attachment A are obtained under existing tariffs. These services are and have been available to other E-Mail providers at the same rates.

Computer storage service enables an enhanced service provider ("ESP") to place its data base into a Bell Atlantic-provided computer. This service will allow ESPs who do not have their own computers to offer information services to

^{2/} While an E-Mail vendor has been tentatively selected, final contractual arrangements have not been completed.

^{3/} Bell Atlantic will also allow a gateway customer with large volumes of E-Mail to access the E-Mail service directly. Billing for E-Mail will be provided as part of the gateway service. Any competing E-Mail provider may obtain identical access and billing arrangements at the same charges. This access arrangement, which was not explicitly set out in Bell Atlantic's CEI Plan, is a natural extension of that Plan, since it employs no new or additional underlying basic Bell Atlantic service or interface which was not included in that Plan as approved.

the public through the gateway. As shown in Attachment B, the ESP's service will be connected to the gateway processor through PDN facilities in the same manner as will any other ESP, and the end user will not be aware that the ESP's information is stored in a Bell Atlantic computer.

Approval of these adjunct services will allow Bell Atlantic to offer its gateway customers a wider array of information services. Inclusion of E-Mail service will make gateway service more attractive and thus enlarge the end user base. Provision of storage service will reduce computer costs for smaller information providers and thus encouraging competition by reducing barriers to entry. The public will benefit through the availability of a wider variety of information services. For these reasons, Bell Atlantic requests expedited review and approval of this amendment.

Respectfully submitted,

The Bell Atlantic Telephone
Companies

By Their Attorneys

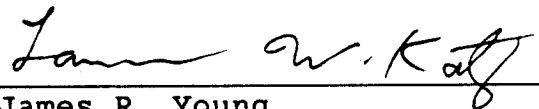

James R. Young
Lawrence W. Katz

Mark J. Mathis
Of Counsel

1710 H Street, N.W.
Washington, D.C. 20006
(202) 392-6580

October 7, 1988

BELL ATLANTIC E-MAIL

1. Enhanced Service Description

Electronic Mail or E-Mail is a service which provides for the composition, transmission, storage and delivery of messages. An E-Mail message is created by a user typically from a terminal device such as a personal computer. The originator of an E-Mail message also identifies the intended recipient or recipients. The E-Mail system receives this information, routes, stores, and delivers the message.

E-Mail messages may have a variety of characteristics. The message may be a free-form spontaneous composition such as a casual letter. It may be a simple standardized message or form that is sent frequently to a common group of users. The messages may be simple text, more complicated encoded data such as spreadsheets, or complex standardized business documents such as purchase order forms. Bell Atlantic's E-Mail service will support and facilitate each of these forms of electronic messaging.

E-Mail provides several benefits to users including increased productivity, especially when sending messages to multiple destinations, and when standard formats are used. It also increases accuracy of messages and provides faster document transmission.

a. Message Creation

A subscriber to Bell Atlantic's E-Mail service will have several options for creating a message. One method will be to use the software stored in the Bell Atlantic E-Mail system. Under this option, the originator of the message uses a modem-equipped personal computer to access the E-Mail system which then prompts the user through each step necessary to construct a message. This process is referred to as on-line message creation. This message creation option allows new and occasional users to learn the system without an investment in personal computer software.

Another message creation option for the E-Mail user will be to purchase compatible personal computer software which is generally available from a number of suppliers, including Bell Atlantic. This software contains the necessary instructions and functionality to enable the user to compose a message on their computer without being connected to the network or to any other device. This process is referred to as off-line message creation, which provides a cost-effective way for larger volume users to create and transmit messages.

b. E-Mail Features

Bell Atlantic's E-Mail service provides a central storage facility or mail box for each user as part of the E-Mail processor. Messages designated for a user are stored in the mail box until accessed by the recipient.

Additional features that will be available with Bell Atlantic's E-Mail service include:

- (1) Broadcast Delivery - the ability to broadcast messages simultaneously to multiple addresses;
- (2) Bulletin Board - the creation of an information exchange between user groups with a unique user identification number;
- (3) Binary File Transfer - the transmission of a stored file of processed data in its processed form enabling the recipient to immediately use the information without reformatting;
- (4) Special Print Deliveries - the ability to deliver messages to various print devices including facsimile, Telex and stand-alone paper printers and;
- (5) X.400 Interface - the ability to interconnect a variety of divergent public and private E-Mail systems through the use of the emerging X.400 international standard protocol.

The X.400 interface feature is of particular significance since it allows for mass market development by eliminating the interconnection limitations created by the introduction of proprietary systems. Use of X.400 will enable users of Bell Atlantic E-Mail to send and receive messages from most other E-Mail systems worldwide.

2. End User Access To E-Mail

There are a variety of means to access the Bell Atlantic E-Mail service.

The primary means of reaching Bell Atlantic E-Mail service is via the Bell Atlantic Gateway. The user first calls the local Gateway access number. Following Gateway sign-on procedures, the user selects Bell Atlantic E-Mail from the menu. Connection is then made to the E-Mail system via Bell Atlantic or interLATA facilities, as appropriate. These are depicted in the following diagrams. The Gateway then logs the user into the E-Mail service, thus saving the user time and simplifying the login procedure. Upon entry of a valid password, all features of Bell Atlantic's E-Mail are then available to the user.

Gateway subscribers may also reach Bell Atlantic's E-Mail without going through the Gateway Menu. E-Mail can be reached by calling either the local Bell Atlantic Public Data Network access number or that of an interLATA service provider, if appropriate. Upon call completion, the E-Mail service login sequence must then be followed, including personal identification and password. At this point all features of the E-Mail service are available and the customer will be billed through the Gateway.

If the user has elected to purchase personal computer software and create an "offline" message, access is similar to those described above.

3. Basic Services Required For Bell Atlantic's E-Mail

The underlying basic services and interfaces required for E-Mail are those set out in Bell Atlantic's CEI Plan for Gateway service.

Bell Atlantic E-Mail service, as illustrated in the following diagrams, is accessed through either Bell Atlantic's Public Data Network or, if interLATA transport is required, by an interLATA service provider.

To support intraLATA traffic, the E-Mail service will purchase Public Data Network (PDN) port(s), with an associated private line facility specified in the PDN tariff, and will pay PDN usage charges for traffic delivered to the E-Mail processor at the same rates charged to any other subscriber to these services. These components are noted on the attached diagrams for both the Pennsylvania and Washington area Gateway trials. All basic services underlying E-Mail service were described in the Gateway CEI Plan for which tariff pages were submitted.

InterLATA connections will be provided by an interLATA service provider selected by the E-Mail user. No basic services will be purchased by the E-Mail service for interLATA connections as all such basic services necessary to provide interexchange connectivity will be provided by the interLATA service provider (see attached diagram). Although not reflected in the E-Mail interLATA access diagram, the interLATA service provider can choose to terminate its interLATA E-Mail traffic at the local PDN in lieu of directly terminating at the E-Mail processor.

4. E-Mail Relationship to Bell Atlantic's Gateway

Billing for Bell Atlantic's E-Mail service is through Bell Atlantic's Gateway service. The E-Mail processor will record sufficient call detail on all E-Mail usage, such as message size, time of call and specific E-Mail features employed, to allow the Gateway to generate complete, accurate billing information.

Whether or not users access the E-Mail service through the Gateway, they must subscribe to the Gateway in order to have access to Bell Atlantic's E-Mail service. Larger customers generally have system administrators whose functions will be made easier through the consolidated billing information the Gateway can generate. Residence and small business customers will find access simplified and their billing easier to understand when they use the Bell Atlantic Gateway to connect to Bell Atlantic's E-Mail service.

The ability of Bell Atlantic to offer its E-Mail service in conjunction with its Gateway service should not be underestimated. Its presence on the Bell Atlantic Gateway will allow for more widespread availability of E-Mail for consumers and small businesses, thus creating a true mass market. Further, the combination of a friendly and easy-to-use service with time-saving functionality, such as E-Mail, and the ease of access provided by the Gateway, should encourage additional consumers to begin experimentation with and use of information services in general.

E-MAIL INTRALATA ACCESS WASHINGTON AREA TRIAL

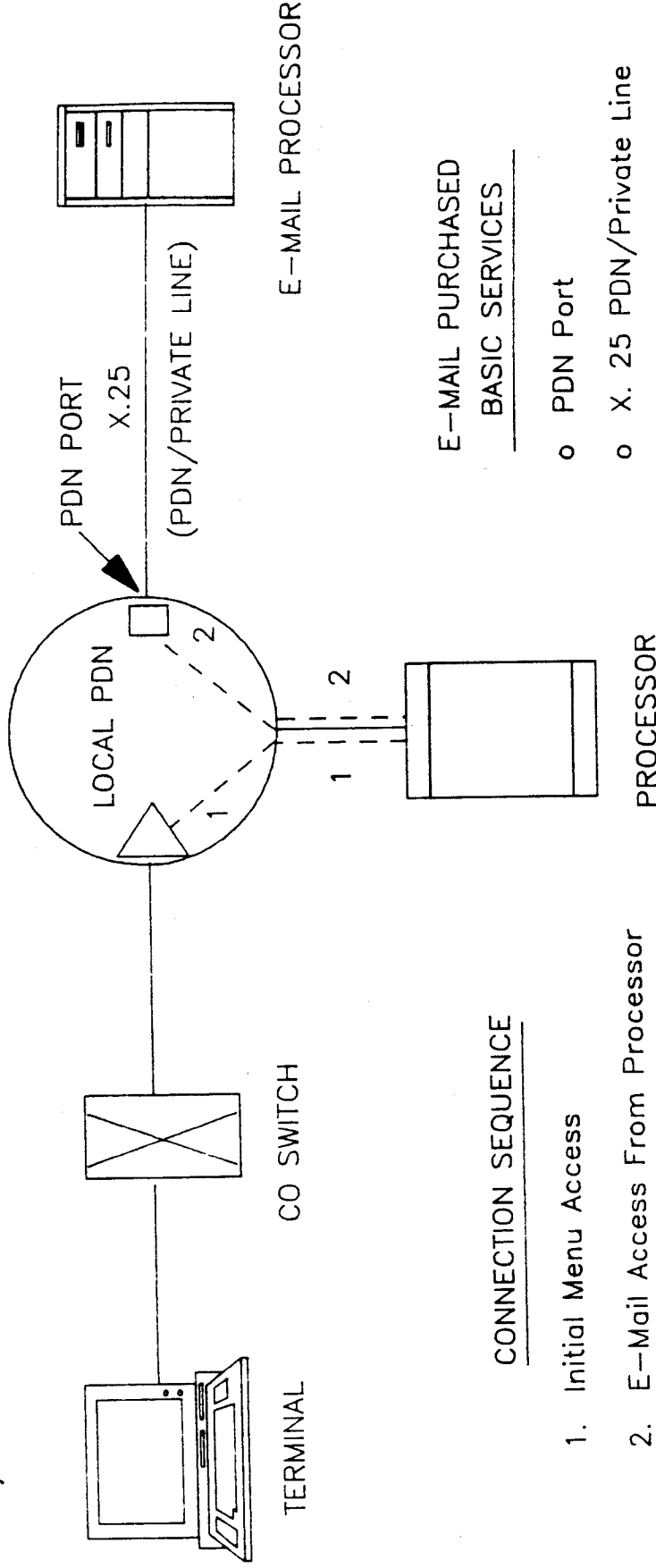

CONNECTION SEQUENCE

1. Initial Menu Access
 2. E-Mail Access From Processor
- E-Mail User Communications Path
Consists of Segment 1 Plus Segment 2

E-MAIL PURCHASED BASIC SERVICES

- o PDN Port
- o X.25 PDN/Private Line

E-MAIL ACCESS PENNSYLVANIA TRIAL*

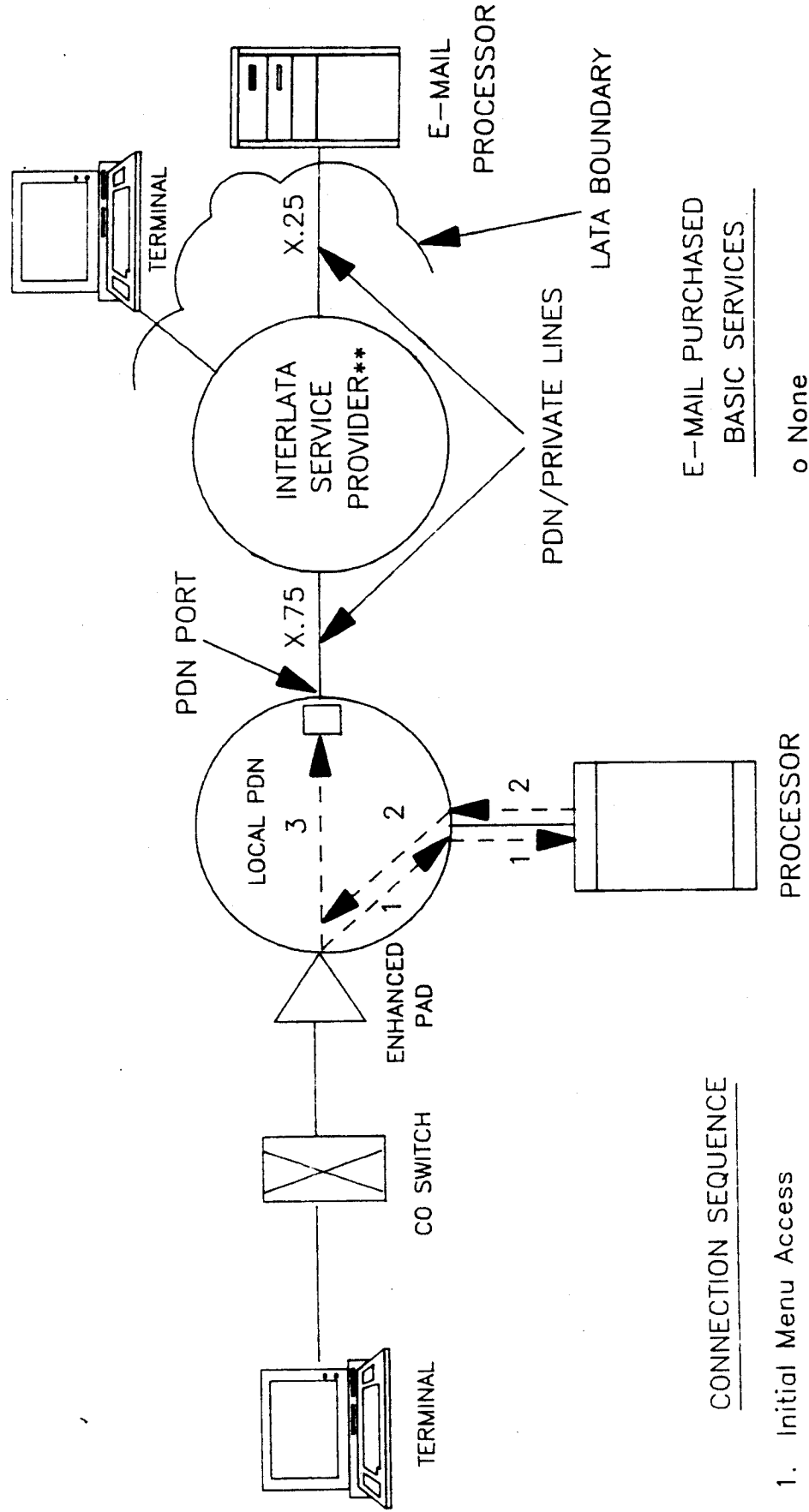

CONNECTION SEQUENCE

1. Initial Menu Access
2. E-Mail Routing Information From Processor
3. E-Mail User Communications Path

E-MAIL PURCHASED
BASIC SERVICES

o None

* InterLATA Service Provider Connections
are Identical for Washington Trial

** Selected by the End User

BELL ATLANTIC STORAGE SERVICE

1. Enhanced Service Description

Bell Atlantic's Storage service will offer computer storage capacity to information providers (IPs) who do not have or do not wish to use their own computers to offer their information services to the public. IPs will be able to use any software that is technically compatible with the operating system used by Bell Atlantic's Storage service.

IPs will be responsible for loading and updating their own information to the Bell Atlantic Storage service and may use any of four possible methods: magnetic tape, magnetic diskette, remote download, or on-line data entry. Remote download and on-line data entry will take place via dial-up, leased line, or packet switching network.

For update purposes, a unique telephone number and/or data network address will be available to IPs to enter information via Bell Atlantic's PDN service or local switched network. An IP may also use its private line facilities to enter its updated information. The update number/address will bring up an editing welcome banner, and will prompt for user ID and password. Upon successfully entering this information, the IP will be given access to his information service for on-line editing.

Updates can also be performed via remote download, on a computer-to-computer basis. Information held remotely in an IP's computer would be transmitted directly to the Bell Atlantic Storage service computer via Bell Atlantic's PDN service or local switched network, or the IP's private line facilities. Magnetic tapes and diskettes may also be physically delivered to the Bell Atlantic Storage service for update processing.

Bell Atlantic's Storage service will purchase and/or lease the host computers used to provide this service. For the Pennsylvania Gateway trial, the storage computer will be remotely located from the centralized processor but both will be within the Philadelphia LATA. In the trial planned for the Washington area, the processor functions and Storage service will initially be performed by one computer but may also use a stand-alone storage facility at a later date.

2. End User Access To IPs On Bell Atlantic's Storage Service

IPs subscribing to Storage service will be listed under their own names on Bell Atlantic's Gateway service menu as services accessible to Gateway users with no indication that they are subscribers to Storage service. The fact that an IP has elected to subscribe to Bell Atlantic's Storage service will therefore be transparent to Gateway users.

Users of Bell Atlantic's Gateway will access IPs residing in Storage service in exactly the same manner as they access any other IP on the Bell Atlantic Gateway. A user will view the Gateway services directory and enters the appropriate mnemonic code for the IP selected. These codes do not indicate on which computers or storage service the IP resides. The mnemonic code selected by the user will be translated to a network address and routed to the PDN for transport to the IP via either the PDN or facilities of an interLATA service provider, if appropriate.

3. Basic Services Required For Storage Service

The underlying basic services required for Storage service are those set out in Bell Atlantic's CEI Plan for Gateway service.

To support intraLATA traffic, the Storage service will be connected to the Gateway through PDN port(s), with an associated private line facility, as specified in the PDN tariff. For the Pennsylvania trial, Bell Atlantic's Storage service will also subscribe to local business exchange service.

Bell Atlantic's Storage service will subscribe to these services at the same rates charged to any other subscriber. All basic services underlying Bell Atlantic's Storage service were described in the Gateway CEI Plan and the tariff pages filed with the Plan.

If an IP subscribing to Bell Atlantic's Storage service desires the ability to terminate interLATA traffic directly to its database, the interLATA connections will be provided by an interLATA service provider selected by the IP. No basic services will be purchased by the Bell Atlantic's Storage service for interLATA connections to the IP. If an interLATA service provider chooses to terminate its interLATA Storage service traffic at the local PDN, the call will be completed over the same PDN facilities described above for Storage service intraLATA traffic.

4. Storage Service Relationship To Bell Atlantic's Gateway

Billing for Bell Atlantic's Storage service is through the Bell Atlantic Gateway. The Storage service computer will record sufficient call detail on all Storage service usage to allow the Gateway to generate complete, accurate billing information.

STORAGE SERVICE INTRALATA ACCESS PENNSYLVANIA TRIAL

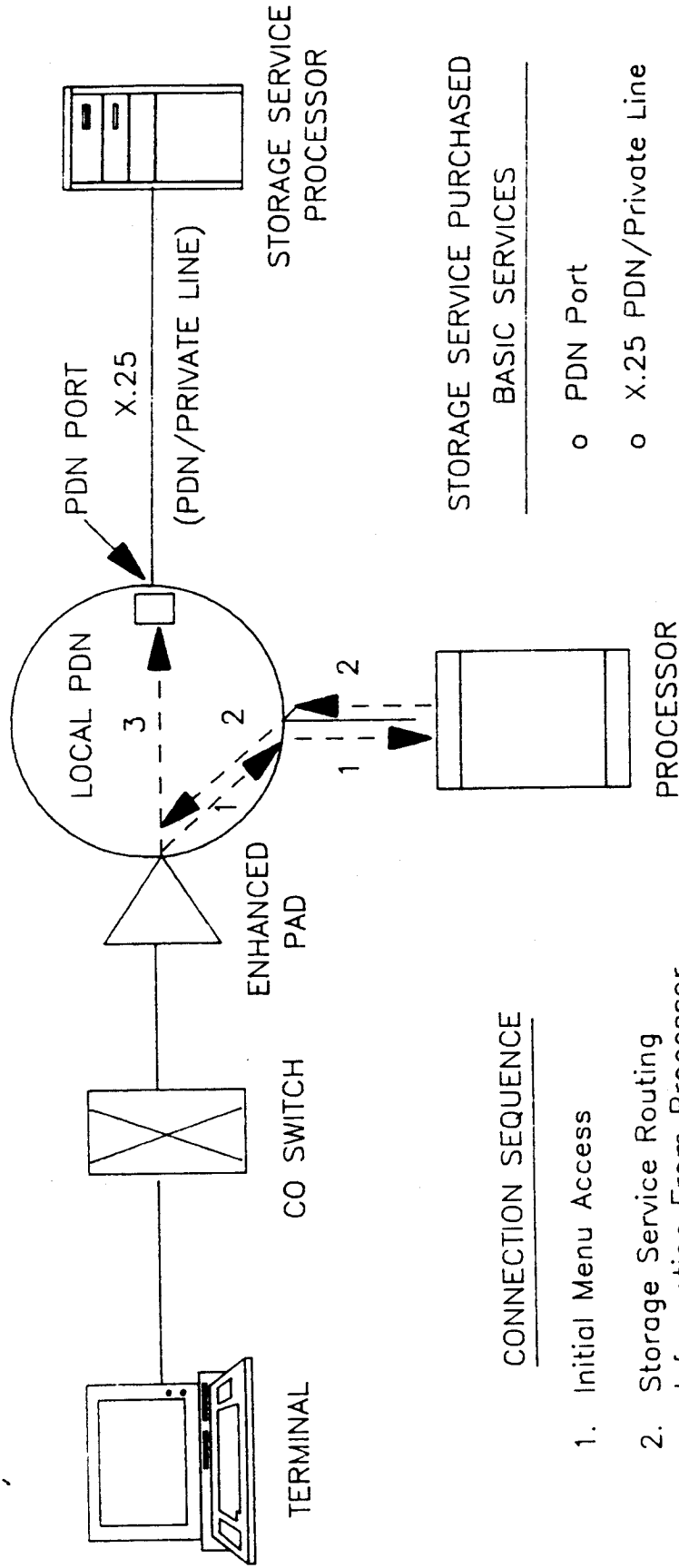

CONNECTION SEQUENCE

1. Initial Menu Access
2. Storage Service Routing Information From Processor
3. User Communications Path

STORAGE SERVICE PURCHASED BASIC SERVICES

- o PDN Port
- o X.25 PDN/Private Line

STORAGE SERVICE INTRALATA ACCESS WASHINGTON AREA TRIAL

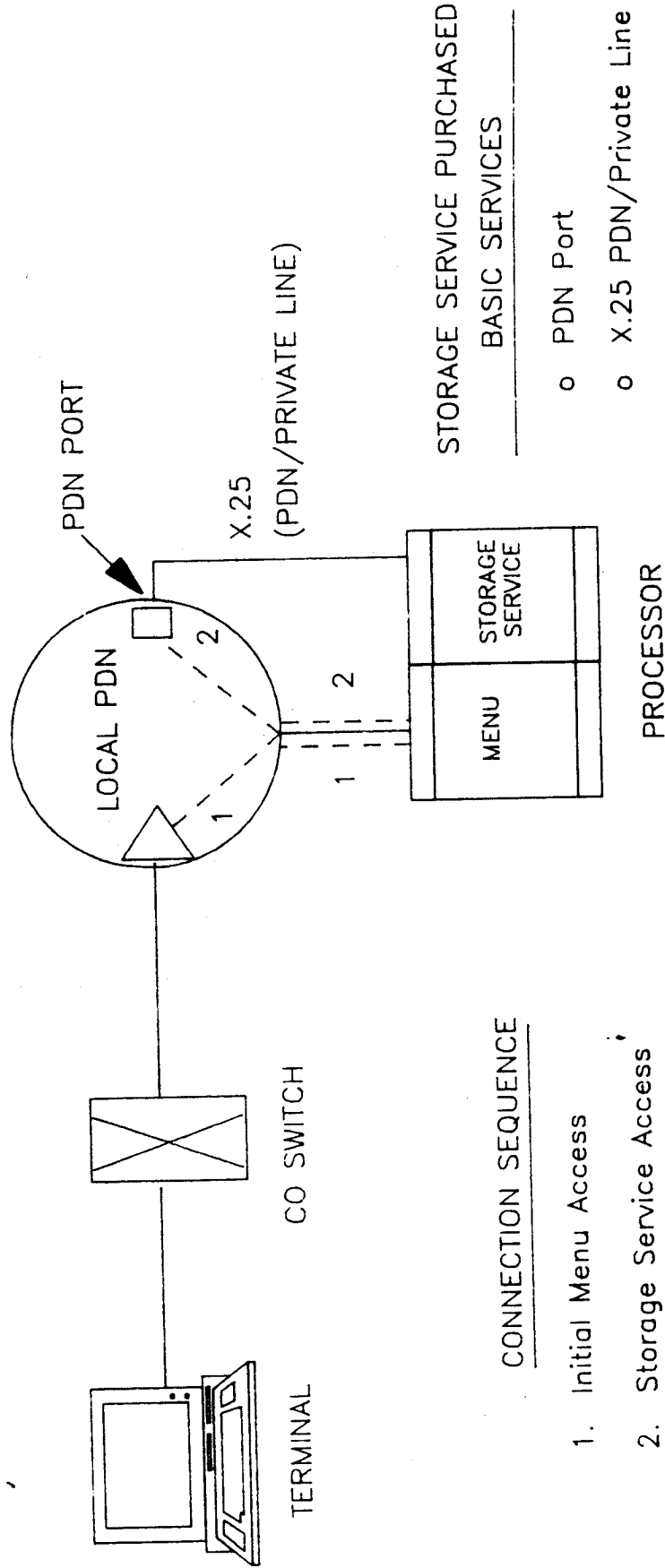

CONNECTION SEQUENCE

1. Initial Menu Access
 2. Storage Service Access From Processor
- User Communications Path Consists of Segment 1 Plus Segment 2

STORAGE SERVICE ACCESS VIA INTERLATA SERVICE PROVIDER PENNSYLVANIA TRIAL*

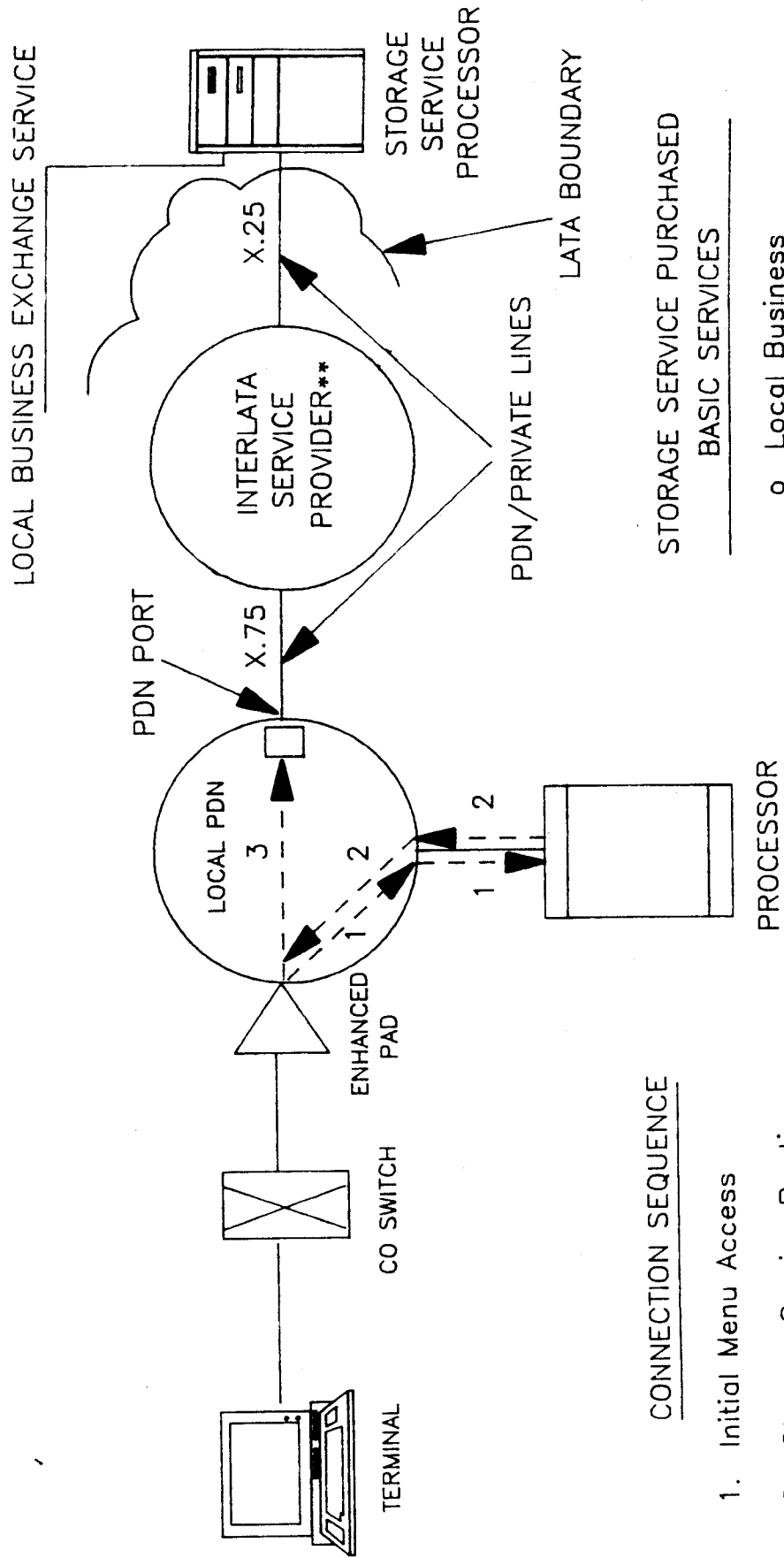

CONNECTION SEQUENCE

1. Initial Menu Access
2. Storage Service Routing Information From Processor
3. Storage Service User Communications Path

STORAGE SERVICE PURCHASED
BASIC SERVICES

- o Local Business Exchange Service

* InterLATA Service Provider Connections are Identical for Washington Trial

** Selected by Information Provider

CERTIFICATE OF SERVICE

I hereby certify that a copy of the foregoing
"Amendment to CEI Plan" was served this 11th day of October,
1988, by mailing thereof by first class mail, postage prepaid,
to the parties on the attached service list.

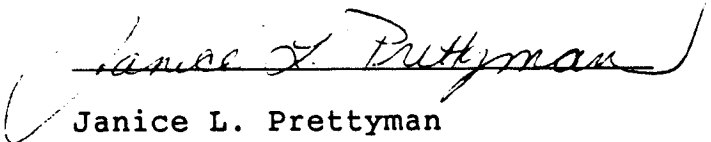
Janice L. Prettyman

Ⓢ COPY

Bell Atlantic

Network Services, Inc.

1710 H Street, N.W. 3rd Floor
Washington, D.C. 20006
(202) 392-6580

Lawrence W. Katz

Attorney

March 15, 1991

RECEIVED

MAR 15 1991

Federal Communications Commission
Office of the Secretary

Ms. Donna R. Searcy, Secretary
Federal Communications Commission
1919 M Street, N.W., Room 222
Washington, D.C. 20554

Re: Amendment of CEI Plans For Voice
Messaging Service, 3 FCC Rcd 5772
(1988), Message Storage Service, 3
FCC Rcd 3553 (1988), and Gateway
Service, 3 FCC Rcd 6045 (1988).

Dear Ms. Searcy:

The Bell Atlantic telephone companies hereby amend their above-referenced comparably efficient interconnection plans to add the service points listed in Attachment A and additional basic services listed in Attachment B.

This filing adds a number of new and, in a few cases, revised service points for Voice Messaging and Message Storage services. They will also now use Uniform Call Distribution, an existing tariffed service. Bell Atlantic's Gateway and Electronic Mail services also plan to use several tariffed basic services and add new service locations. All the services are available to competing enhanced services providers at the same rates, terms and conditions as they are available to Bell Atlantic's enhanced services.

As with earlier minor CEI amendments, Bell Atlantic assumes that this amendment will become effective 14 days from the date of this letter unless informed otherwise. Please contact the undersigned with any questions or comments.

Sincerely,

Lawrence W. Katz

Attachments

cc: Parties of record to Voice Messaging, Message Storage Service, and Gateway CEI Plans.

ATTACHMENT A

Additional Service Locations

Gateway, Computer Storage, and Electronic Mail -- Norfolk LATA

Voice Messaging and Message Storage Service - See Attached List

Offices Scheduled for VMS Deployment 1st Quarter, 1991

Maryland

Sykesville*

Virginia

Winchester
Church 5E
Clearview
Danville 1A
Danville 5E
Hodges Ferry
Randall

West Virginia

Apple Grove
Buffalo
Mason
Point Pleasant
Scott Depot

Washington

Metro DS1

*Represents a change in the deployment schedule

Offices Scheduled for VMS Deployment 2nd Quarter, 1991

West Virginia

Lewisburg
 Alderson
 Greenville
 Meadow Bridge
 Peterstown
 Rainelle
 Union
 White Sulphur Springs
 Clarksburg DMS100
 Glenville
 Jane Lew
 Salem
 Shinnston
 Sutton
 West Milford
 West Union
 Weston
 Morgantown 5E
 Gum Springs
 Suncrest
 Morgantown ORM

Virginia

Bedford
 Staunton 1A
 Staunton 5E
 Stone Mountain
 Pulaski
 Culpeper
 Fredericksburg
 Lee Hill
 Leesburg
 Orange
 Spotsylvania
 Church 1A
 High Street
 West Little Creek
 Yorktown
 Hungary Spring

Washington

Woodley
 Congress Heights
 Metro CGI

New Jersey

Middletown
 Phillipsburg
 Spring Mills
 Trenton 5E
 Woodbury
 Caldwell*
 Cranford*
 Dunellen*
 Eatontown*
 Englishtown*
 Erskine Lakes*
 Fairlawn*
 Fords*
 Hackettstown*
 Holmdel*
 Humbolt*
 Ironbound*
 Jamesburg*
 Lakehurst*
 Little Falls*
 Market 0*
 Market 1*
 Market 2*
 Mendham*
 Mommouth Junction*
 Murray Hill*
 Middletown*

New Jersey Cont'd

Nutley*
 Oakland*
 Perth Amboy*
 Robertsville*
 Rochelle Park*
 South Orange*
 Spotswood*
 Unionville*
 Whippany*
 Wyckoff*
 Union City 5E*
 Bergen 5E*
 Boonton*
 Ocean City*

Pennsylvania

Phoenixville
 Donora
 Ligonier
 Brownsville
 Altoona
 Bloomsburg
 Numedia
 Danville
 Wyoming
 Carbondale
 Nanticoke
 Moosic
 Stroudsburg
 Honedale
 Middletown
 Fayette City
 Elizabeth Twp.
 California
 State College
 Catawissa
 Washingtonville
 Wilkes-Berra
 Plymouth
 Lake Como
 Glen Lyon
 Taylor
 Marshalls Creek
 Belle Vernon
 Monessen
 Chaleroi
 Monongahela
 Kingston
 Millvale
 Berwick
 Moscow
 Olyphant
 Jermy
 Tannersville
 Wallenpaupack
 Pittstown

*Represents a change in the deployment schedule

Offices Scheduled for VMS Deployment 3rd Quarter, 1991

West Virginia

Logan
Bradshaw
Delbarton
Gilbert
Holden
Jaeger
Kermit
Man
Matewan
Omar
Williamson
Clarksburg 5E
Belington
Bridgeport
Gassaway
Grafton
Philippi
Weirton
Chester
Woodsdale
Beech Bottom
Bethany
Valley Grove
Warwood
Wellsburg
West Liberty

Virginia

Franklin Pike
Nettles Drive
Williamsburg
Gaskins
Sandston

Washington

Lincoln

Offices Scheduled for VMS Deployment 4th Quarter, 1991

West Virginia

Parkersburg 5E
Dallison
Elizabeth
Lubeck
Mineral Wells
Pennsboro
Ravenswood
Ripley
Valley Mills
Vienna
Williamstown
Buchannon
Rock Cave
Fairmont
Fairview
Farmington
Mannington
Monongah
Rivesville
Kingwood
Newburg
Rowlesburg
Terra Alta
Tunntleton
Moundsville
Follansbee
Weirton Heights

Virginia

Onancock
Suffolk
Bethia
Colonial Heights
Chester
Hermitage*

Washington

Southeast

New Jersey*

Beaver Brook
Forked River
Paulsboro
Vineland
Wenonah
Wildwood
Belleville
Madison
West Milford
East Dover
Herbertsville
New Brunswick
Spring Lake
Van Hiseville
Wall Township
Washington
Whiting
Landisville
Millville
Mullila Hill
Penns Grove
Pennsville
Port Norris
Salem
Swedesboro
Williamstown
Woodstown

*Represents a change in the deployment schedule

ATTACHMENT B

Additional Underlying Basic Services

Gateway, Computer Storage, and Electronic Mail:

- 800 Service and WATS
- Private Line Service
- Feature Group A
- Special Access Service
- Foreign Exchange Service
- Direct Inward Dialing Service
- Uniform Call Distribution Service
- High Capacity Digital Hand-off Service

Voice Messaging and Message Storage Service:

- Uniform Call Distribution Service

Tariff references for these services are attached. Sample tariff pages for all of these services have previously been provided, with the exception of Digital Handoff Service, for which a sample tariff page is attached.

SERVICETARIFFSECTIONPRIVATE LINE SERVICE

Bell of PA.

Pa. P.U.C. - No. 304

C&P

Maryland

P.S.C. - Md. - No. 204

Virginia

S.C.C. - Va. - No. 204

Washington, D.C.

P.S.C. - D.C. - No. 204

West Virginia

P.S.C. - W.Va. - No. 204

Diamond State

P.S.C. - Del. - No. 1

New Jersey Bell

B.P.U. - N.J. - No. 2

DIRECT INWARD DIALING (DID) SERVICE

Bell of PA.

Pa. P.U.C. - No. 1

26

C&P

Maryland

P.S.C. - Md. - No. 202

2

P.S.C. - Md. - No. 203

6

Virginia

S.C.C. - Va. - No. 202

2

S.C.C. - Va. - No. 203

6

Washington, D.C.

P.S.C. - D.C. - No. 203

6

West Virginia

P.S.C. - W.Va. - No. 202

2

P.S.C. - W.Va. - No. 203

6

Diamond State

P.S.C. - Del. - No. 1

24

New Jersey Bell

B.P.U. - N.J. - No. 2

A5

SERVICETARIFFSECTIONFOREIGN CENTRAL OFFICE SERVICE

Bell of PA.

Pa. P.U.C. - No. 1

12

C&P

Maryland

P.S.C. - Md. - No. 202

1

P.S.C. - Md. - No. 204

3

Virginia

S.C.C. - Va. - No. 202

1

S.C.C. - Va. - No. 204

3

Washington, D.C.

P.S.C. - D.C. - No. 202

1

P.S.C. - D.C. - No. 204

3

West Virginia

P.S.C. - W.Va. - No. 202

1

P.S.C. - W.Va. - No. 204

3

Diamond State

P.S.C. - Del. - No. 1

11

New Jersey Bell

B.P.U. - N.J. - No. 2

A5

800 SVC. AND WATS

Bell of PA.

Pa. P.U.C. - No. 296

C&P

Maryland

P.S.C. - Md. - No. 210

1

2

3

Virginia

S.C.C. - Va. - No. 210

1

Washington, D.C.

Not Available

West Virginia

P.S.C. - W.Va. - No. 210

1

2

3

Diamond State

P.S.C. - Del. - No. 29

New Jersey Bell

B.P.U. - N.J. - No. 2

A7

SERVICETARIFFSECTIONHIGH CAPACITY DIGITAL HAND-OFF SERVICE

Bell of Pa.

Not Available

C&P

Maryland

P.S.C.-Md.-No.204

12A

Virginia

Pending Approval

Washington, D.C.

Pending Approval

West Virginia

Not Available

Diamond State

Not Available

New Jersey Bell

B.P.U.-N.J.-No.2

B9

SERVICE

TARIFF

SECTION

ACCESS SERVICES

Special Access

Bell of PA. Pa. P.U.C. - No. 304 1-7

C&P

Maryland 217 7
Virginia 217 7
Washington, D.C. Not Available
West Virginia 217 7

Diamond State Not Available

New Jersey Bell B.P.U. - N.J. - No. 2 7

Bell Atlantic - Interstate

Special Access F.C.C. No. 1 7

Switched Access

Feature Group A F.C.C. No. 1 6

SERVICETARIFFSECTIONUNIFORM CALL DISTRIBUTION SERVICE

Bell of Pa.

Not Available

C&P

Maryland

P.S.C.-Md.-No.203

6

Virginia

Admin. Guidelines

7

Washington, D.C.

Pending Approval

West Virginia

P.S.C.-W.Va.-No.203

6

Diamond State

Pending Approval

New Jersey Bell

Pending Approval