



# LIDB Storage Service

*We'll set up and maintain your LIDB information and monitor for fraud. Free.*

In fact, if you meet certain qualifications, we'll manage and maintain your LIDB (Line Information Database) – and pay you.

You receive all the advantages of LIDB storage and none of the costs. When you use Verizon's LIDB, your subscribers can be out of your service area and bill calls to calling cards and home or office numbers. With Verizon's LIDB Storage Service, you'll also be able to offer subscribers enhanced services such as Caller Name Delivery.

## Why offer such a valuable service free?

There is no service initiation fee, no charges for daily maintenance, no charges for updating and no

charge for fraud monitoring. We do, however, charge carriers who access your line information. Those revenues support the service you receive. In fact, if you meet certain qualifications, we'll share those revenues with you.

## Easy to set up, easy to access

You simply provide us with your line information – mail it on electronic tape, disk or paper or fax it. We'll load the data and continuously update it at no cost.

Access is just as easy. Strategically located gateway Signal Transfer Points in Verizon's national Common Channel Signaling System 7 network can minimize transport costs. (For details, see the information on our LIBD Access product.)

## Proactive fraud monitoring

Verizon is nationally recognized for its leadership in fraud detection and prevention technology. As part of the LIDB Storage Service, we will continuously monitor and track your subscribers' use of Alternate Billed Services – collect calls, calls

charged to calling cards and calls billed to third numbers. We will immediately investigate any potential fraud detected by our systems.

## Ways you'll use LIDB data

With Verizon's LIDB Storage Service, you'll be able to quickly, accurately and cost effectively:

- Validate calling card calls.
- Screen and validate billed numbers for collect and third-number billed calls.
- Screen and reject calls to be charged to pay phones.
- Provide Caller Name service.
- Route incoming calls to a multi-location subscriber's closest location (Single Number Service).
- Offer advanced services as they are developed.

## For more information on free LIDB storage

Just talk to your Verizon Account Manager. During the discussion, be sure to ask about our LIDB Storage Revenue Sharing Program and Premium Bundled Services Discount Program. Contact us through our Web site at [verizon.com/wholesale](http://verizon.com/wholesale).

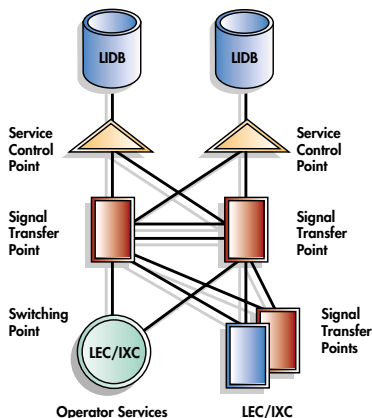

Serving area only includes the former GTE territories in AL, CA, FL, HI, ID, IL, IN, KY, MI, MO, NC, NV, OH, OR, PA, SC, TX, VA, WA and WI.

©2000 Verizon Communications

**[verizon.com/wholesale](http://verizon.com/wholesale)**

Control No. 6051A 11/00